

ID2202

INFRARED PHOTODETECTOR

Installation, use and maintenance manual

Contents

1	INTRODUCTION	24
1.1	OPERATING PRINCIPLE	24
1.2	FIELDS OF APPLICATION	24
2	TECHNICAL SPECIFICATIONS	25
3	DESCRIPTION	26
3.1	EXTERNAL APPEARANCE	26
3.2	ELECTRICAL INTERFACE	27
3.3	SENSITIVITY CONTROL POTENTIOMETER.....	29
3.4	LED LAMPS	29
4	REPLACING ID2000 AND ID2200 MODELS.....	31
4.1	INPUT AND OUTPUT COMPATIBILITY	31
5	INSTALLATION.....	32
5.1	SAFETY	32
5.2	TRANSPORT	32
5.3	POSITIONING	32
5.4	PROTECTION FROM LIGHT RADIATION.....	35
5.5	COOLING.....	36
5.6	SIGHTING	36
5.7	SENSITIVITY CONTROL	36
6	MAINTENANCE.....	38
6.1	OPERATIONAL TEST.....	38
6.2	PERIODIC INSPECTIONS.....	38
6.3	CLEANING THE OPTICAL WINDOW.....	38
6.4	REPLACING THE OPTICAL WINDOW.....	38
6.5	TROUBLESHOOTING	39
7	CONTENT OF THE PACKAGE SUPPLIED	40
8	SPARE PARTS / ACCESSORIES.....	40
9	ADDITIONAL INFORMATION.....	41
9.1	OVERALL DIMENSIONS	41
10	TECHNICAL ASSISTANCE	42

1 INTRODUCTION

The ID2202 (code D.A. 5122000031) is a device, of the ON/OFF type, that detects the presence of hot materials, that is to say, materials that emit infrared radiation (IR).

The ID2202 can replace, with additional functions and improved features, the ID2200 and ID2000 models.

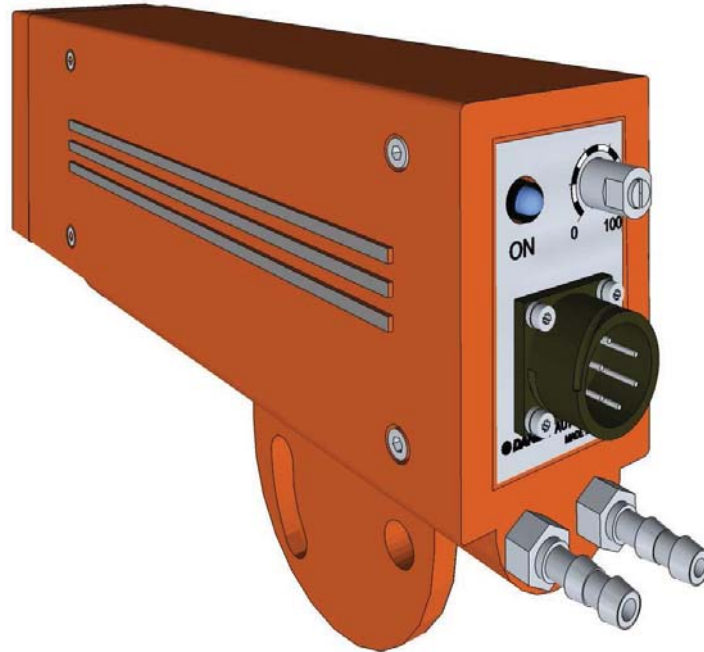

1. Photodetector ID2202

1.1 OPERATING PRINCIPLE

The ID2202 uses an IR sensor to measure the quantity of infrared radiation that is present in its field of view.

A digital output is activated in the presence of hot material, or when the output signal of the sensor IR exceeds a threshold value, which can be set by a potentiometer.

A second digital output provides an indication of the reliability of the detection, signalling anomalies in its functioning or excessive closeness to the threshold of detection, and therefore a possible error.

A digital input allows you to select the HMD sensitivity, so as to ensure a reliable detection of both 'cold' ($T > 450^{\circ}\text{C}$), and 'hot' ($T > 650^{\circ}\text{C}$) materials.

1.2 FIELDS OF APPLICATION

The ID2202 is designed specifically for use in steel hot rolling mill plants, but it can also be used in similar applications (i.e. continuous casting, or detection of the presence of hot bodies in non-ferrous metals).

The manufacturing characteristics of the photodetector make it suitable for use in heavy industrial environments.

The photodetector is prepared for electrical supply by low-voltage continuous current. The output connectors are protected against overloads and over voltages.

2 TECHNICAL SPECIFICATIONS

Detectable spectrum	850 .. 1700 nm
Temperature of the object to be detected	≥ 450°C (842°F) HIGH sensitivity ≥ 650°C (1202°F) LOW sensitivity
Distance of detection (fig. 7)	500 .. 2,000 mm
Range of the observation field (fig. 8)	vertical: 12° horizontal: 3°
Digital inputs	24 Vdc / 5 mA
Digital outputs	PNP, I _{max} = 200 mA, output connections protected against short circuits.
Response time	
ON	typ. 0.2 ms (min 0.1, max 0.3 ms)
OFF	typ. 0.3 ms (min 0.2, max 0.5 ms)
Power supply	rated voltage 24 Vdc (20 .. 32Vdc) @ 50mA
Power supply of cooling device	water, filtered < 300 µm, 3-5 L/min @ 0.2 bar, 2 bar max 1/4" GAS threads
Working temperature	-40 .. +70 °C (-40 .. 158 °F)
Storage temperature	-40 .. +70 °C (-40 .. 158 °F)
Degree of protection	IP66 (NEMA 4X)
Dimensions (not including connectors)	266 x 180 x 64 mm (10.5" x 7.1" x 2.5")
Weight	1.7 kg (3.7 lb)

3 DESCRIPTION

3.1 EXTERNAL APPEARANCE

The container of photodetector ID2202 (1), made of pressure-cast aluminium, is equipped with a semi-circular support plate (2) that allows its fastening and orientation on the vertical plane within an angle of about 30°, and incorporates a circuit for liquid cooling (3), to be supplied with water or other refrigeration fluids based upon the working environmental conditions.

There is an optical window (4) on the front side through which the IR sensor inside the HMD “observes” the material to detect.

A green LED, that is inside the HMD, can be seen through the optical window.

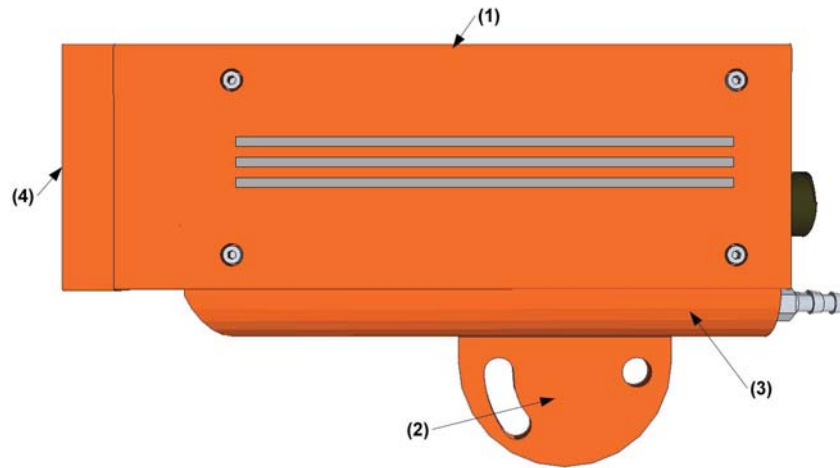

2. Exterior appearance

On the rear side of the photodetector there are the following connection and signalling devices:

- bayonet connector, 6 contacts, directive MIL-C-5015 (5)
- two-colour red/green LED (6)
- potentiometer to adjust sensitivity (7)
- 1/4" GAS threads to supply and drain the cooling circuit (8).

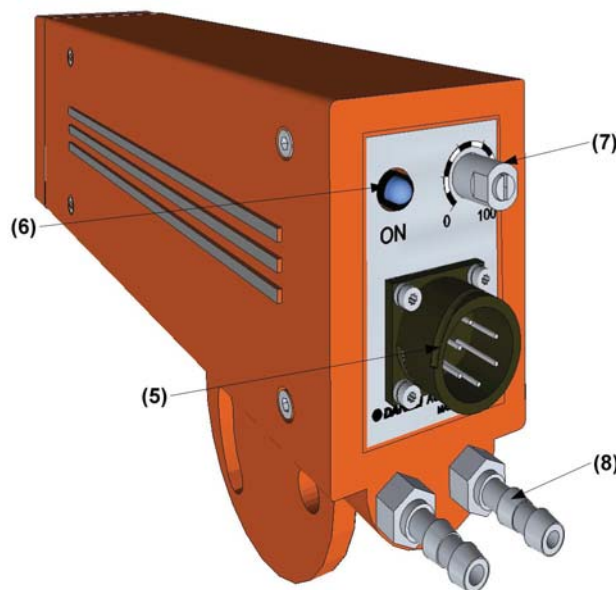

3. Rear view

3.2 ELECTRICAL INTERFACE

All the signals are reported to the 6-pole circular connector, MIL-C-5015 type, located on the rear side of the photodetector.

We recommend cabling the signals of the connector to an intermediate junction box located near the rolling line, easily accessed for inspection and maintenance. The junction box should represent the connection point with the automation system.

An armor-plated festoon with the circular connector on one side and open wires on the other, is available as an accessory (see chapter 8).

Pin	Signal	Function
A	+24VDC	Power input
D	0VDC	
C	MATP	Presence of material, digital output PNP
B	HEALTHY	Reliable detection, digital output PNP
F	TEST	Test, digital input
E	SSEL	Sensitivity selection, digital input

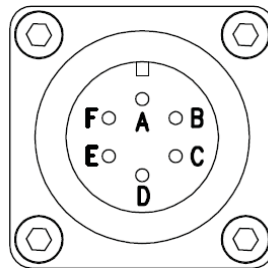

4. Circular connector

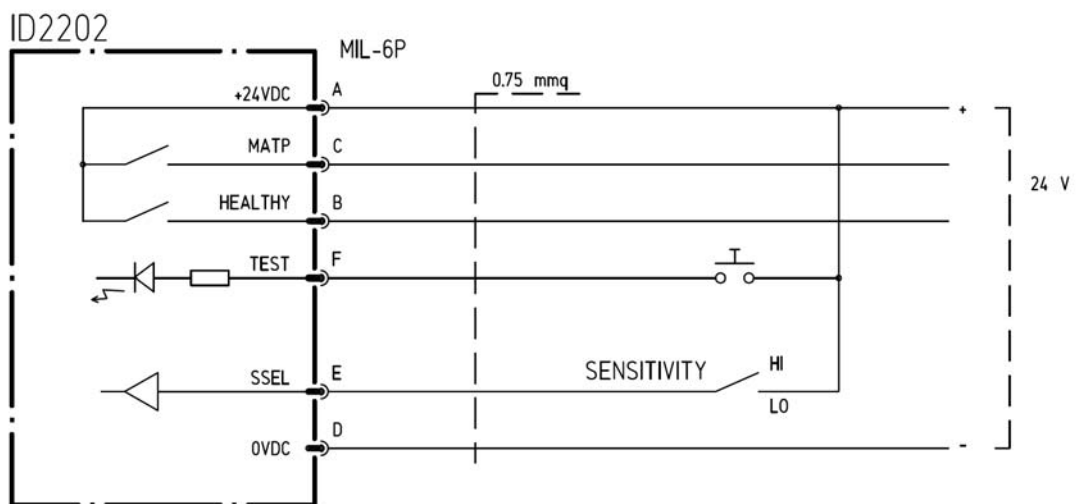

5. Electrical connections

➤ **MATP – presence of material**

The MATP digital output is activated when an infrared source of intensity sufficient to exceed the detection threshold, which is determined by the sensitivity selection (“coarse” control) and the position of potentiometer (“fine” control), is detected.

➤ **HEALTHY – reliable detection**

The HEALTHY digital output is normally activated and deactivated when one of the anomalies indicated below is present:

- the IR signal received is near the threshold, and therefore the detection is uncertain
- the TEST input is activated but the IR sensor does not detect a sufficient signal
- internal overheating
- absence of power supply

Simultaneously with the deactivation of the HEALTHY output, the anomaly is indicated also by the two-colour LED located on the rear of the ID2202.

➤ **TEST – self-test**

When enabled, an IR LED located in front of the sensor is switched on, causing the MATP output to activate.

➤ **SSEL – sensitivity selection**

It is possible to select the “coarse” sensitivity of the detector ID2202 by activating or not the SSEL digital input, that is to say connecting it or not to the power supply.

The potentiometer located on the rear panel provides the fine control.

SSEL	Sensitivity
OFF	HIGH (like ID2200)
ON	LOW (like ID2000)

The SSEL input may be:

- wired to the opposite connector (fixed sensitivity setting)
- reported on an external clamp with a configuration jumper
- piloted by a PLC output, to set dynamically the sensitivity according to the temperature of the material to detect.

Note that, if the SSEL input is not connected, the sensitivity selected is HIGH.

 **ATTENTION !**

It is necessary to set the sensitivity on HIGH if the temperature of the material is near the lower measurable limit.

We recommend not using the HIGH selection if not necessary, given that it increases the probability of detection of sources outside the process (reflections of material or solar radiation).

3.3 SENSITIVITY CONTROL POTENTIOMETER

The single-turn potentiometer, located on the rear panel, provides the fine control of the material presence threshold and also allows you to set the ID2202 detection sensitivity. The potentiometer's shaft is equipped with a shock-proof protection and can be activated by means of a screwdriver.

The diagram shows the minimum detectable temperature for a rolled product having 10 mm diameter, placed at a distance of 500 mm from the front glass, depending on the position of the potentiometer, and according to the selected sensitivity through SSEL input.

For instance, if the potentiometer is at 100% (maximum sensitivity), the minimum detectable temperature is 450°C if SSEL = OFF (high sensitivity), or about 640°C if SSEL = ON (low sensitivity).

The minimum detectable temperature varies according to the rolled product diameter and distance.

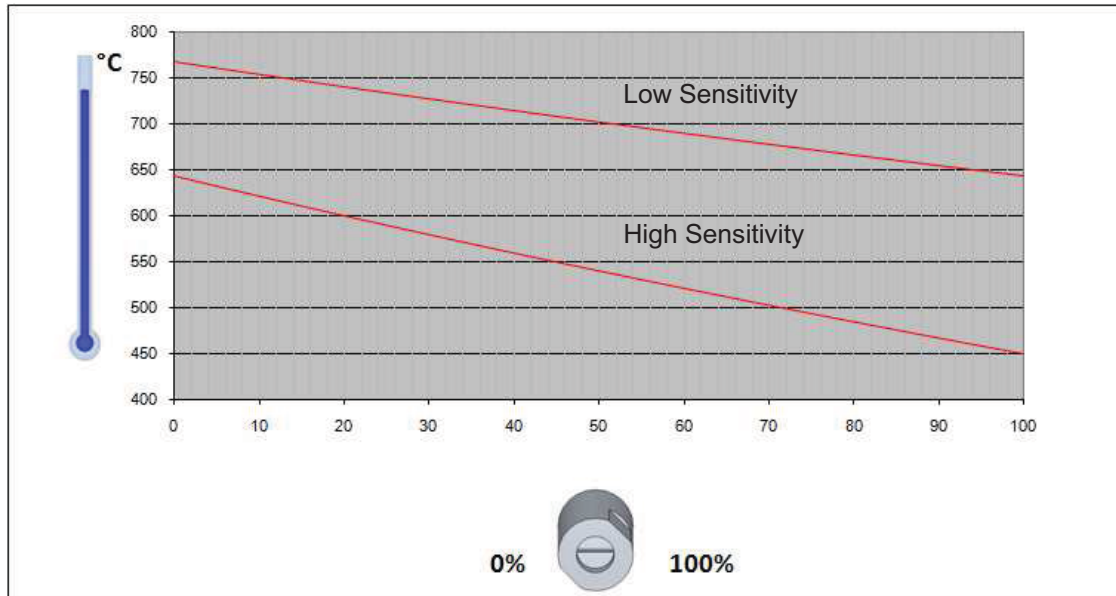

6. Minimum detectable temperature depending on the potentiometer position

3.4 LED LAMPS

There are two: one front LED lamp and a rear LED lamp.

The **front** LED, high-brightness green, that can be seen through the optical window, is activated along with the rear green LED and at the MATP output when presence of material is detected.

The LED allows the operator, provided with an electric torch (with filament lamp) to identify where the ID2202 field of view is. The operator comes in front of the HMD and moves the torch (aimed at the HMD) in the area where it is assumed the HMD' field of view is. Sighting can be precisely identified by the corresponding switching on of the LED.

The two-toned green/red LED on the **rear** panel is activated in the following conditions:

- the green colour switches on in the presence of material
- if the light intensity received is near the threshold of material detection, the red light flashes more and more rapidly as the threshold comes closer (at the same time the HEALTHY output is deactivated)
- the red light flashes slowly for internal overheating (at the same time the HEALTHY output is deactivated).

The red light flash in the absence of a bar indicates that the background light detected in the reading field is too strong and might compromise the accuracy of the reading.

The red light flash in the presence of a bar (together with the activation of the green-coloured LED) indicates that the signal is weak and therefore very close to the threshold of detection that determines the presence of the bar.

The following table summarises the signals of the rear LED.

Rear LED status	Description	Output status	Suggestions
GREEN LED = OFF RED LED = OFF	ABSENCE OF MATERIAL, or photocell switched off RELIABLE DETECTION (if photocell switched on)	MATP = OFF HEALTHY = ON (if photocell switched on)	
GREEN LED = OFF RED LED = Short pulses	ABSENCE OF MATERIAL Signal near the threshold of presence of material (anyway below the threshold) The LED flashes more and more frequently as the signal approaches the threshold	MATP = OFF HEALTHY = OFF	Verify / improve the proper sighting and/or installation
GREEN LED = ON RED LED = Short pulses	PRESENCE OF MATERIAL Signal near the threshold of presence of material (anyway above the threshold) The LED flashes more and more frequently as the signal approaches the threshold Detection is NOT RELIABLE	MATP = ON HEALTHY = OFF	Material is too cold or selection of sensitivity is inadequate
GREEN LED = ON RED LED = OFF	PRESENCE OF MATERIAL Signal beyond the threshold of presence of material. Detection is reliable	MATP = ON HEALTHY = ON	
GREEN LED = OFF RED LED = 1Hz Flashes	<u>OVERHEATING</u> The photocell can keep operating normally.	MATP = ON/OFF according to the presence or not of material HEALTHY = OFF	Analyse what causes the overheating: - exposure to sources of heat - excessive ambient temperature

4 REPLACING ID2000 AND ID2200 MODELS

The ID2202 is designed to replace, with improved features, the following models:

- ID2000: HMD for high temperatures
- ID2200: HMD for low temperatures

Improved features are:

- SSEL input to select the sensitivity, depending on its setting, thus allowing to use the ID2202 both as ID2000 and ID2200. So it is possible to use just one HMD's model in several parts of the plant, where the rolled product temperature is different.
- The SSEL input allows using the ID2202 in plant areas where the rolled product temperature is high or low depending on the product, for instance at the exit of a water box that can be switched On or Off. To set the most appropriate sensitivity is sufficient that automation controls adequately the SSEL input.
- The ID2202 horizontal visual angle is narrower and more accurate as to ID2000 and ID2200, so that accuracy of detection is improved.
- If the ID2202 is used to replace ID2000 (SSEL=1), its insensitivity to sunlight is 100 times more than ID2000's.
- Two-toned rear LED which signals when the IR signal received is near the presence of material threshold, and therefore the detection is uncertain
- Digital output to signal proximity to the presence of material threshold, and other malfunctions.
- Front LED of presence of material (in addition to the rear one) so as to make easier the sighting check.

4.1 INPUT AND OUTPUT COMPATIBILITY

the ID2202 is electrically compatible with ID2000 and ID2200 models, with the following exceptions:

- the ID2202, differently from ID2000 and ID2200, does not have the NPN output of presence of material (pin B). On this pin ID2202 has the HEALTHY output, PNP type
- To enable the test function, it is necessary that ID2000 and ID2200 apply a 24V between the pins F and E. In ID2202, instead, the test function is enabled by applying 24V just on pin F, whilst pin E is used as input for selecting the SSEL sensitivity.

Example **ID2200**, wired as follows:

- only the PNP output of presence of material is used (the most common case)
- the TEST function is enabled by applying 24V to pin F and 0V to pin E.

In this case it is possible to replace ID2200 with ID2202, without any wiring change. Since the pin E is connected to 0V, ID2202 shall have a high sensitivity setting, that is a sensitivity similar to ID2200.

Thus, change of wiring is avoided, but obviously the additional functions of ID2202 (SSEL output and HEALTHY) are lost. If HMD is installed at the exit of a water box which may be off or on (therefore HMD should detect a hot or cold material), it may be advisable cabling at least the SSEL input to a PLC so as to dynamically set sensitivity.

Example **ID2000**, wired as follows:

- only the PNP output of presence of material is used (the most common case)
- the TEST function is enabled by applying 24V to pin F and 0V to pin E.

In this case ID2000 can be replaced by ID2202, but it is necessary to change cabling so as to connect the pin E (SSEL) to 24V, and then to set low sensitivity (similar to ID2000).

As an alternative the original wiring can be kept and the adjusting potentiometer be turned to the minimum. The resulting sensitivity shall be similar to that of ID2000.

5 INSTALLATION

To obtain the maximum reliability of detection it is necessary to effect a correct installation of the detector, taking into account the field of measurement, the minimum dimension of the material as a function of distance, and applying the precautionary measures reported here below.

5.1 SAFETY

The ID2202 photodetectors are intrinsically safe devices because they operate at a low voltage and do not have dangerous parts. However, they should be used and maintained only by skilled personnel who are fully acquainted and comply with all the instructions contained in this manual.

5.2 TRANSPORT

All parts of the photodetector are transported in a box. Inside the box there are suitable polystyrene compartments for the safe transport of the device. The package should be kept so as to be used for transport in case of extraordinary maintenance or repair.

5.3 POSITIONING

The distance between the photodetector and the material to detect must be determined following the indications given in the diagram of fig. 7.

In the diagram, for SSEL = OFF (SENS = HI, HIGH sensitivity) and SSEL = ON (SENS = LOW, LOW sensitivity) respectively, lines represent the maximum installation distance based on different diameters of the rolled product.

The diagram gives the value of the permissible maximum installation distance for the operator, according to the estimated or measured temperature of the material.



ATTENTION !

The diagram gives the maximum distance of use. We recommend to install the HMD at a lower distance than the maximum allowed, for ex. at 60% so as to maintain an adequate margin of safety for detection.

$$D_{optimum} \leq 60\% \times D_{max}$$

On the contrary, when rolling hot products, with a very short distance the photodetector may become overheated.

Example

The ID2202 must be installed to detect a material with minimum temperature of 480°C, and a minimum dimension of 10mm. What is the ideal distance for installation?

Should ID2202 detect “low” temperatures, it must be set with high sensitivity (SENS = HI).

In the diagram, curve corresponding to D=10, shows a maximum distance of about 800mm.

The ideal distance for installation should be less than 60% the maximum distance, for instance 480mm.

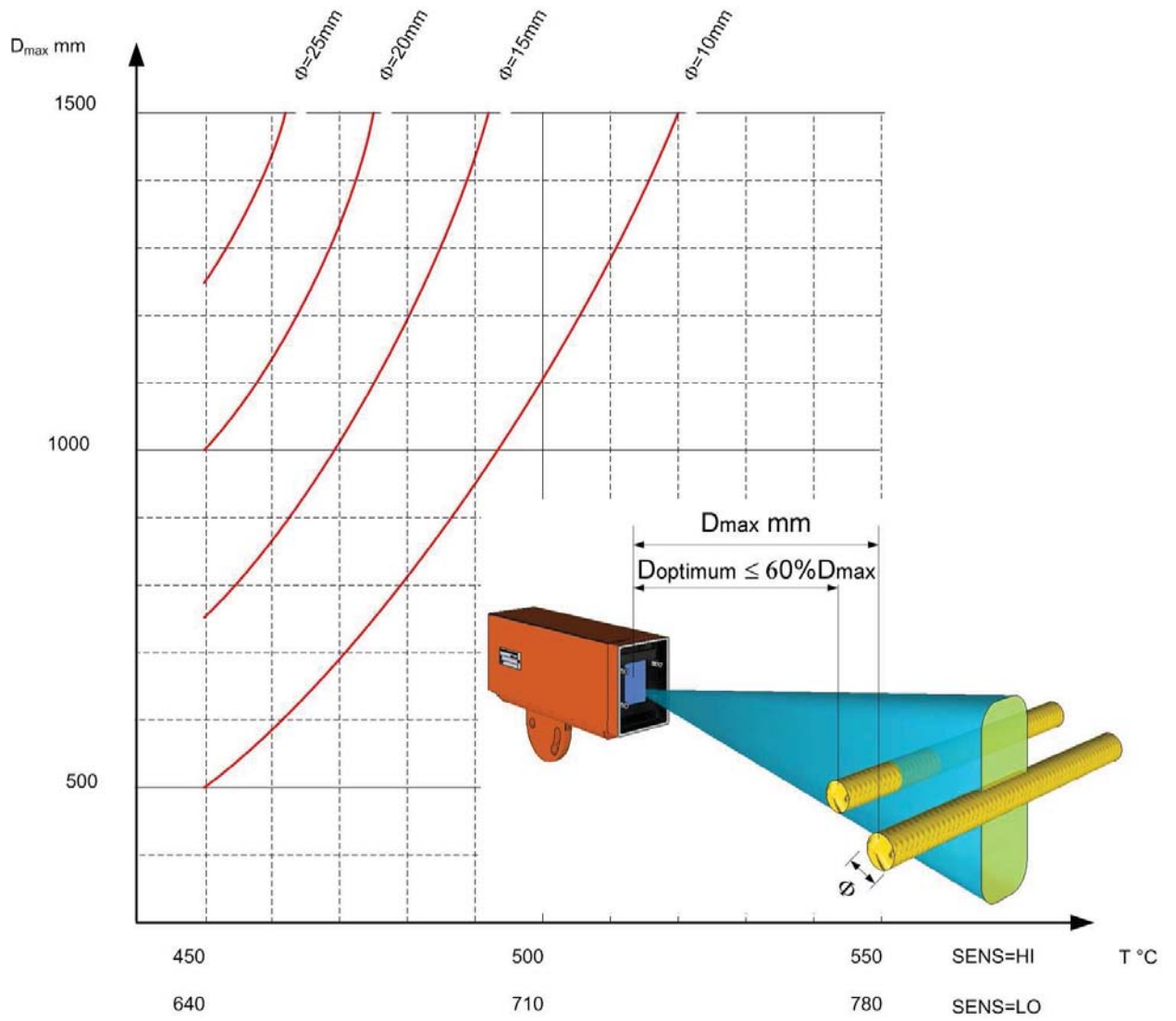

7. Maximum distance of use varies according to the rolled product's temperature and dimension.

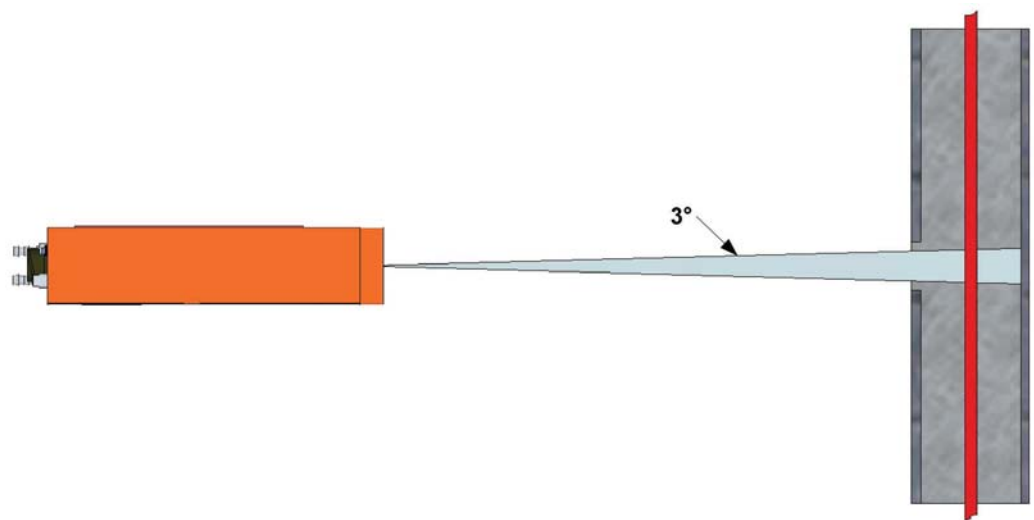

8. Angle of horizontal reading

Figure 9 shows the width of the field of measurement based upon the distance of use. The field of view is essentially a rectangle with the dimensions shown in the figure.

The detector must be placed at such a distance that the field of measurement covers all the positions in which it can find material to be detected.

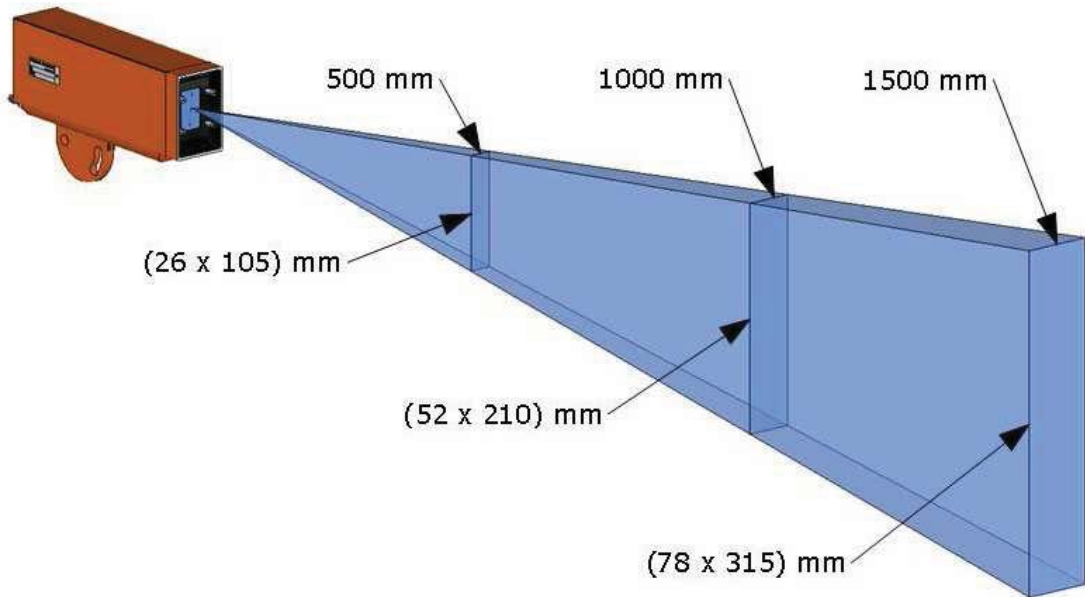

9. Material detection field in relation to distance

The ID2202 is normally installed to the side or above the rolling line. Avoiding a down to top orientation would be better because dust and scale could soil the optical window, preventing its correct operation. When possible it is better to install the ID2202 to the side of the line.

It is necessary to avoid that fumes or steam reduce the visibility of the material, preventing a correct measurement (fumes and steam may be removed blowing air at low discharges, using for example an industrial fan).



ATTENTION !

Avoid fastening the detector onto structures subject to vibrations.

Between the detector and bars there must not be any objects, still or moving, that can interfere with detection.

It may be opportune to equip the photodetector with mechanical and additional thermal protection that guard it against accidental impacts or direct radiation from material. In figure 14 we see a possible example of support with protection, designed to permit, when necessary, rapid access for any operations of adjustment and/or maintenance.

If protection is present between the material and the detector, arrange that protection with a window of sufficient width so that the material is visible for a section long at least as the detection field width.

5.4 PROTECTION FROM LIGHT RADIATION

It is necessary to avoid sources of light or infrared radiation extraneous to the process (light-bulbs, windows, reflections from the rolled product, etc.) that might be within the observation field of the detector.

Correct installation shown in fig. 10: the observation field of ID2202 is from top to down, while a screen protects it from external light sources.

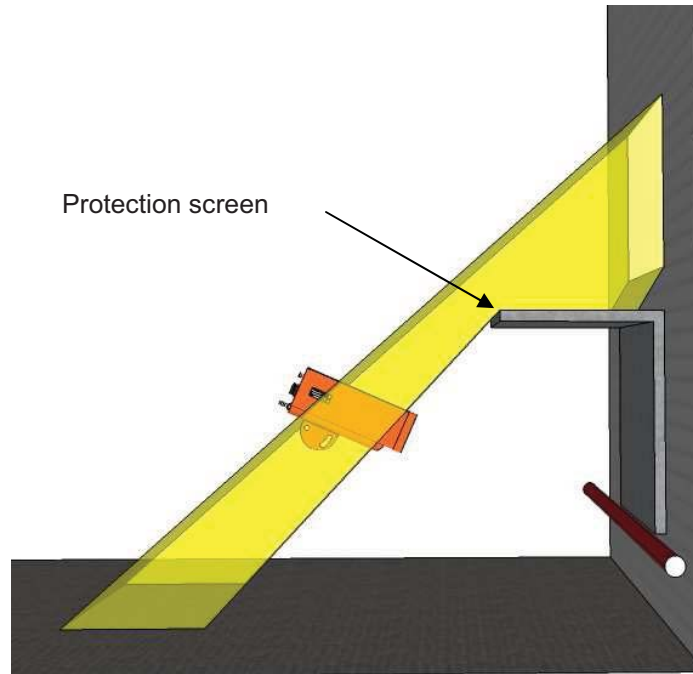

10. Example of correct positioning

Incorrect installation shown in fig. 11:

- ❑ the observation field of ID2202 is from down to top (non opportune)
- ❑ light sources affect the ID2202, thus increasing the risk of incorrect detection.

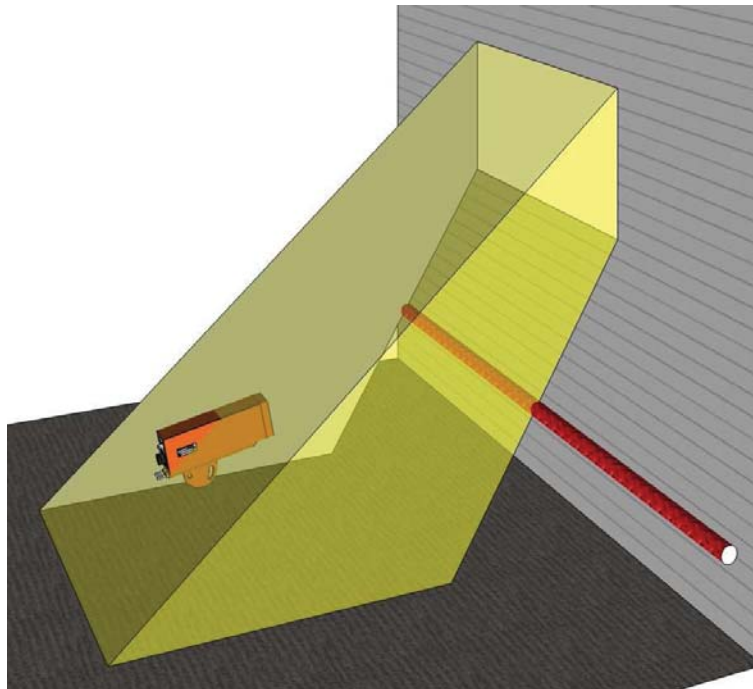

11. Example of incorrect positioning

NOTE: if set to “LOW sensitivity” (instead of "HIGH"), the detection threshold is higher, and the ID2202 is able to operate in conditions of greater background light.



ATTENTION !

The presence of reflective surfaces within the reading field of the ID2202 (for example ducts or rolls) may cause uncertainties in the reading, and are therefore to be avoided. A non-reflective screen must be present behind the rolled product (opaque black), better if built-in, to avoid that light reverberations might reach the detector.

5.5 COOLING

If the ambient temperature is likely to exceed 60 °C it is opportune to activate the cooling circuit provided on the photodetector body to reduce the temperature so that it falls within the maximum limit.



ATTENTION !

Water (or other refrigeration fluid) must be used only in real need. Excessive cooling of the photodetector body with respect to the ambient temperature may cause the formation of condensation, due to environment humidity, on the device itself and on the glass window, with consequent risks for its correct functioning.

If the cause of the higher temperature of the photodetector is radiation deriving from the rolled product, we recommend the use of protective screens against the radiation, generally a more effective solution than water cooling.

In the event of overheating due to direct radiation, which cannot be avoided, use a cooled protection (see chapter 8).

5.6 SIGHTING

To verify sighting, use an infrared source – for example an electric torch or a piece of heated bar – positioned in the area where the material will move, pointed toward the optical window of the ID2202. Verification occurs by moving the torch throughout the area in which the material will be located, and checking for the corresponding activation of the bar presence indicator.

5.7 SENSITIVITY CONTROL

The ID2202 is provided with an input for the “coarse” sensitivity control (SSEL), and with a potentiometer for the fine control.

The potentiometer setting can be typically maintained at 100% and act only on the SSEL input.

- If the material to detect is always “hot”, set SSEL=1 (low sensitivity)
- If the material to detect is always “cold”, set SSEL=0 (high sensitivity)
- When the temperature of the material may be high or low, depending on the rolling process, wire the SSEL to a PLC output and control it opportunely according to the optimal sensitivity.

Especially when the ID2202 is set to high sensitivity, it could be useful, anyway, to act on the adjusting potentiometer, for instance in the occurrence of false detection, or when, in the absence of the bar, the red LED flashes to indicate that the signal level is near the threshold value.

The ideal condition, in fact, will be that:

- ❑ in the absence of material, the green LED is off, the red LED not flashing (which, anyway, would indicate that the sensor detects a light level that is near the detection threshold)
- ❑ in the presence of material, the green LED is on, the red LED not flashing (which, anyway, would indicate that the IR signal is low and near the detection threshold).

In the first case (flashing in the absence of material) we recommend reducing sensitivity, while in the second case it would be better to increase it.

LED flashing can be useful to determine the low limit of sensitivity and to define a safety margin.

- ❑ in the presence of material, when rolling a “cold” material of small size, reduce sensitivity until the LED starts flashing slowly, which means that a detection threshold is approaching.
- ❑ From this position increase again sensitivity until the LED stops flashing, then turn slightly the potentiometer so as to get a reasonable margin of detection.

Please remember that the HEALTHY output is disabled when the amount of IR signal is near the threshold, that is when the LED lamp starts flashing. If this output is wired at a PLC output, it can be used to check when the threshold is approaching, what affects reliability of detection negatively (incorrect detection or loss of detection).

6 MAINTENANCE

6.1 OPERATIONAL TEST

The TEST input enables an infrared source inside the photodetector, in front of the sensor, to switch on. The MATP output is enabled accordingly.

This action allows verification of the correct functioning of the optical electronic devices and the links between the detector and the equipment connected.

A test sequence may be activated by the system automation, in the time intervals during which the bar to detect is not present (ghost rolling).

6.2 PERIODIC INSPECTIONS

Periodic preventive maintenance of the photodetector includes the following inspections:

- Check that sighting is correct, using an incandescent bulb located in the area in which the material to be measured will move
- Check that screening of ambient lighting is correct, using the information provided by the warning lamp in the absence of bars
- Check that photodetector is fastened to its support: stability and sighting.
- Check the optical path and remove any deposits of scale that may form in the detection field
- Check that protections supplied with the device are in working order.
- Check the glass window of the photodetector, clean or replace, if necessary.
- Check connector and electrical cable condition, clean or replace, if necessary.



ATTENTION !

Do not use water machine for the external cleaning of the photodetector.

6.3 CLEANING THE OPTICAL WINDOW

A clean cloth must be used to clean the optical window, paying attention not to scratch the glass

6.4 REPLACING THE OPTICAL WINDOW

Replacement of the optical window becomes necessary when it is seriously damaged (scratched or broken) or insufficiently transparent.

The replacement operation must be performed in a clean environment, for example in an office. Clean the outside of the detector if dirty, so as to avoid dirt falling into the device during replacement of the window. The operator's hands must also be clean.

To replace the optical window:

- Remove the 4 screws that fasten the glass locking flange
- Remove the glass and replace
- Carry out the operations above in reverse order, paying particular attention to the assembly of the seal located between the glass and the detector.

6.5 TROUBLESHOOTING

Whenever a malfunction of the photodetector is signalled, proceed as follows:

- Carry out the checks indicated in the periodic maintenance, as explained in chapter 6.2.
- Check functioning by the Self-Test (chapter 3.2).

If the Self-Test works:

- check the glass window condition, clean or replace, if necessary
- check the sighting and adjust, if necessary
- verify sensitivity setting according to the object to detect

If the Self-Test does not work:

- check that the power supply is present,
- check the connector,
- check the external cabling.

7 CONTENT OF THE PACKAGE SUPPLIED

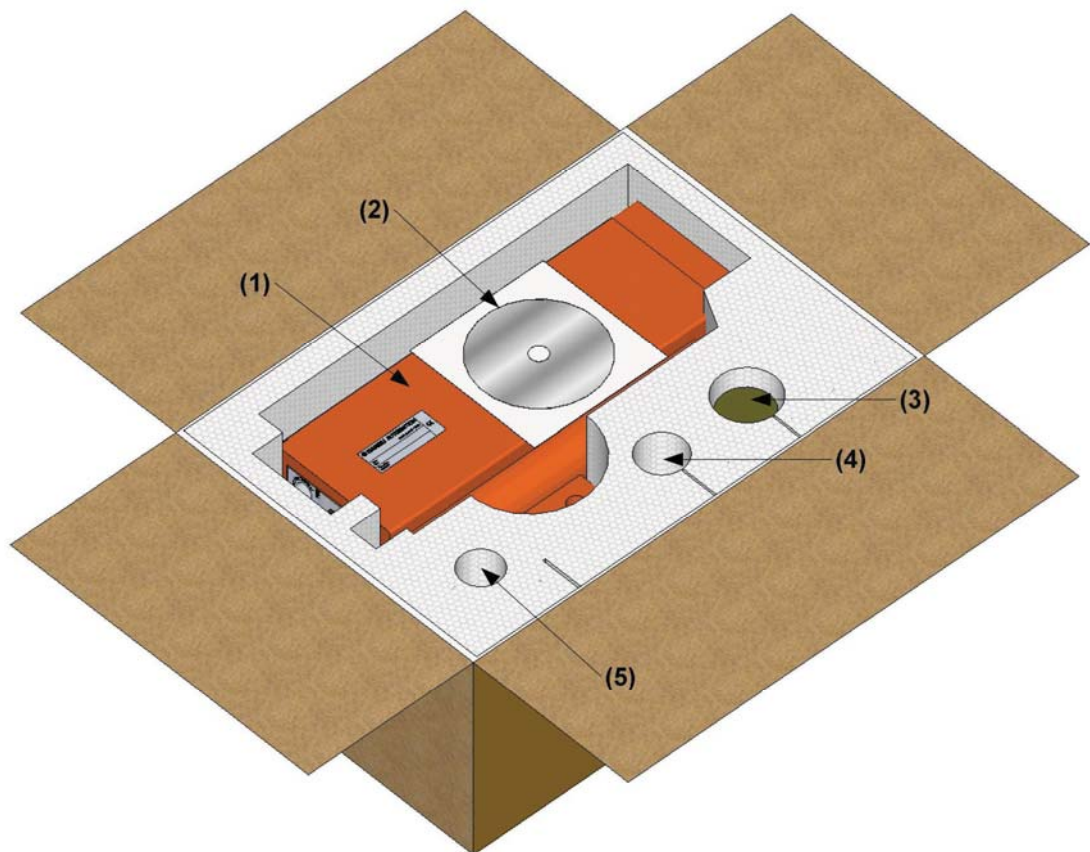

- (1) ID2202
- (2) CD plus Quick Reference
- (3) Connector MIL 6P –F
- (4) Cap
- (5) Replacement glass

12. Complete supply

8 SPARE PARTS / ACCESSORIES

Description	Code D.A.
Complete ID2202 detector	5122000031
6 pole F-connector, MIL type	3349000175
F-connector adapter	3349000263
Protection glass	3985000035
Connection festoon, L=2.8m (9.2 ft)	5331000114
Cooled protection	5915000475
Front protection with air cleaning	5915000450

9 ADDITIONAL INFORMATION

9.1 OVERALL DIMENSIONS

Figure 13 shows the overall dimensions of the photodetector.

Figure 14 shows an example of construction of a support, designed to contain and protect the ID2202 photodetector.

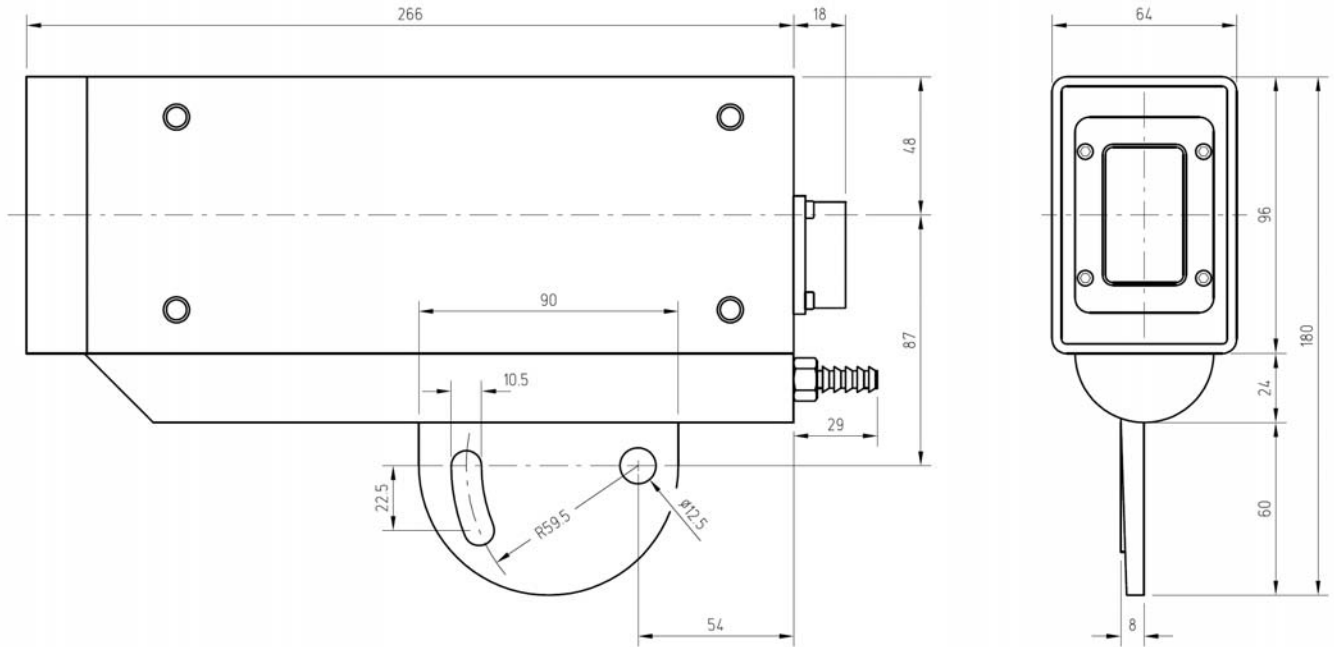

13. Dimensions of the detector (DIN reference mm)

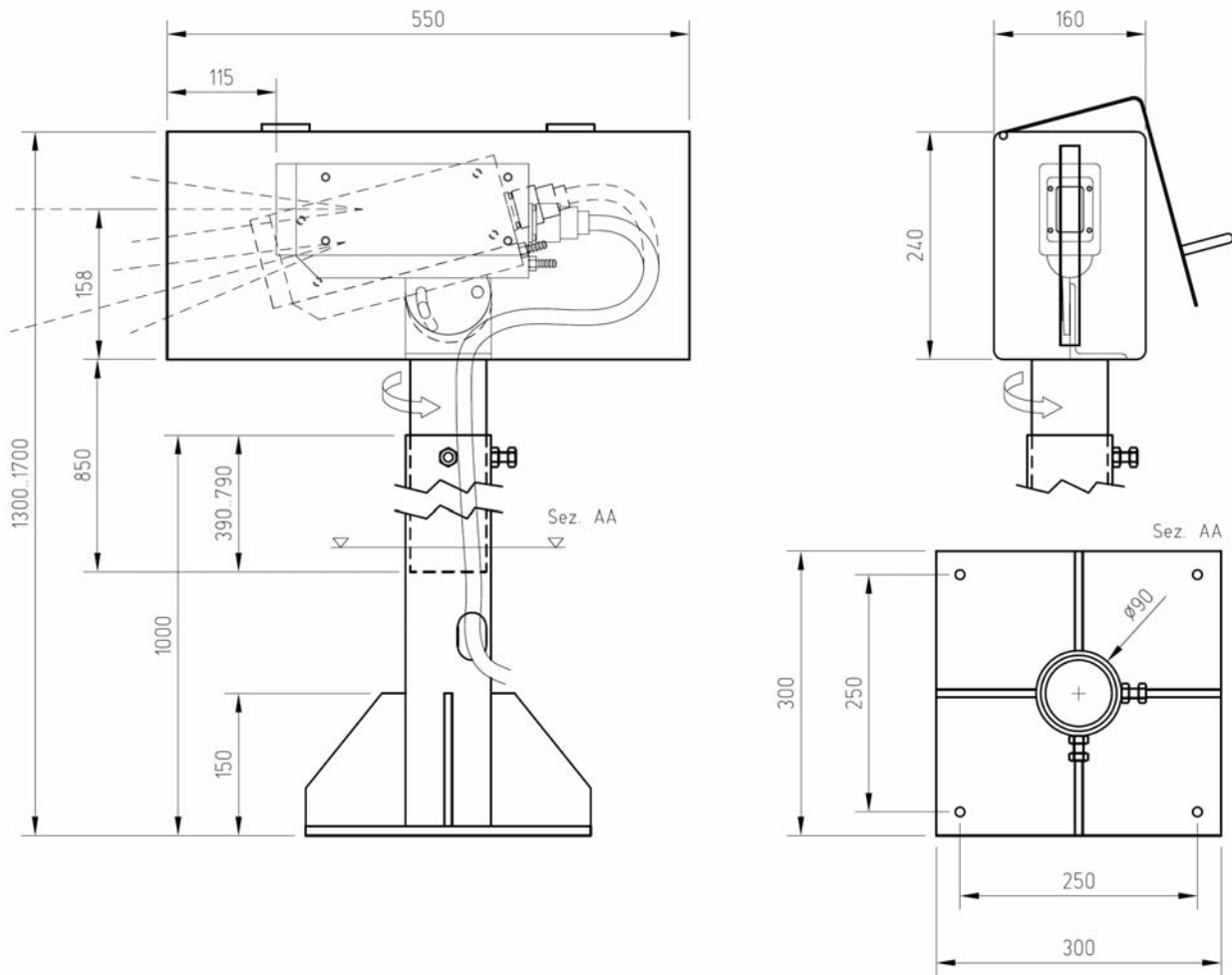

14. Recommended support (DIN reference mm)

10 TECHNICAL ASSISTANCE

DANIELI AUTOMATION technical assistance service is available to provide users with information and explanations, and to obtain the support necessary for repairs and maintenance.

Contact the customer assistance office by phone, fax or e-mail:

tel: +39 0432 518999

fax: +39 0432 518188

e-mail: service@dca.it