

Characteristics

The D1VW with explosion proof solenoids is based on the standard D1VW series. The specific solenoid design allows the usage in hazardous environments.

The explosion proof class is

CE Ex II 2 G
Ex e mb II T4 Gb

for use in zone 1 and 2 (according to ATEX). Additionally the solenoids are IECEx compliant.

All explosion proof solenoids are DC design. The valves for AC operate with integrated rectifier.

For further explosion proof valves please refer to catalogue MSG11-3343/UK.

Download of the PDF file at www.parker.com/ISDE, see "Support".

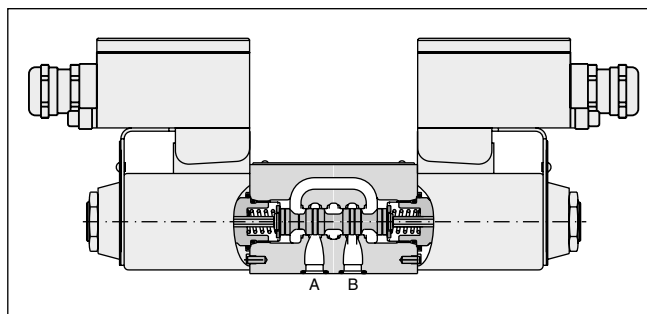
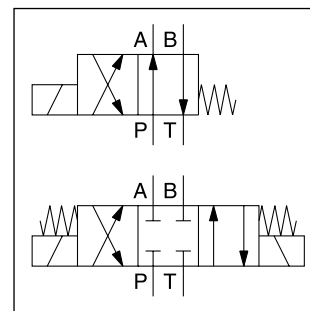
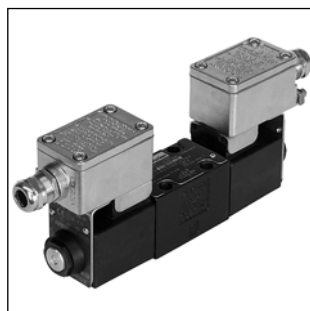

Technical data

General				
Design	Directional spool valve			
Actuation	Solenoid			
Size	DIN NG06 / CETOP 03 / NFPA D03			
Mounting interface	DIN 24340 A6 / ISO 4401 / CETOP RP 121-H / NFPA D03			
Mounting position	unrestricted, preferably horizontal			
Ambient temperature	[°C] -20 ... +60			
MTTF _D	[years] 150			
Weight	[kg] 1.8 (1 solenoid), 2.7 (2 solenoids)			
Hydraulic				
Max. operating pressure	[bar] P, A B: 350; T: 210			
Fluid	Hydraulic oil according to DIN 51524			
Fluid temperature	[°C] -20 ... +60			
Viscosity permitted	[cSt] / [mm ² /s] 2.8 ... 400			
Viscosity recommended	[cSt] / [mm ² /s] 30 ... 80			
Filtration	ISO 4406 (1999); 18/16/13			
Flow max.	[l/min] 60 (see shift limits)			
Leakage at 50 bar	[ml/min] Up to 10 per flow path, depending on spool			
Static / Dynamic				
Step response at 95 %	[ms] Energized: 32 (DC), 40 (AC) De-energized: 40 (DC), 75 (AC)			
Electrical characteristics				
Duty ratio	100 % ED; CAUTION: coil temperature up to 135 °C possible			
Max. switching frequency	[1/h] 15000 (DC), 7200 (AC)			
Protection class	CE Ex II 2 G, Ex e mb II T4 Gb, IP66 (plugged and mounted correctly)			
	Code	J	N	P
Supply voltage / ripple	[V]	24 V =	230/50 Hz	110/50 Hz
Tolerance supply voltage	[%]	±10	±10	±10
Current consumption	[A]	1.0	0.12	0.25
Power consumption	[W]	24	24	24
Solenoid connection	Box with M20x1.5 entry for cable glands. Solenoid identification as per ISO 9461.			
Wiring min.	[mm ²]	3 x 1.5 recommended		
Wiring length max.	[m]	50 recommended		

With electrical connections the protective conductor (PE \downarrow) must be connected according to the relevant regulations.

Ordering Code

**Directional Control Valve
Series D1VW Explosion Proof**

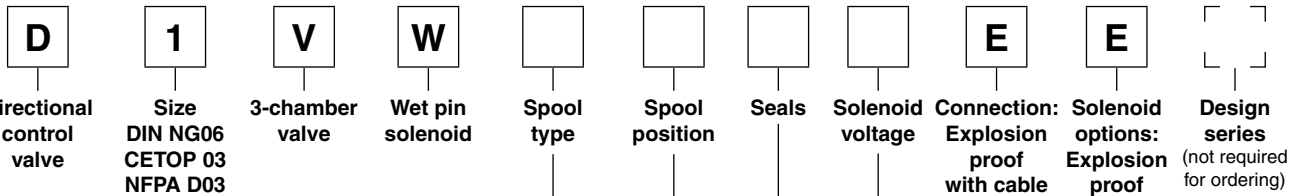

D
Directional control valve

1
Size
DIN NG06
CETOP 03
NFFPA D03

V
3-chamber valve

W
Wet pin solenoid

Spool type

Spool position

Seals

Solenoid voltage

Connection: Explosion proof with cable glands

Solenoid options: Explosion proof Ex e mb II and IECEx conformity

Design series
(not required for ordering)

3 position spools	
Code	Spool type
	a 0 b
001	
002	
003	
004	
005	
006	
007	
008 1)	
009 1)	
010	
011	
014	
015	
016	
021	
022	
081	
082	
102	

2 position spools	
Code	Spool type
	a b
020	
026	
030	
101	

Code	Voltage
J	24 V=
P	110 V 50 Hz
N	230 V 50 Hz

Code	Seals
N	NBR
V	FPM

3 position spools		
Code	Spool position	
C		3 positions. Spring offset in position "0". Operated in position "a" or "b".
	Standard	Spool type 008, 009
E		2 positions. Spring offset in position "0". Operated in position "a".
		Operated in position "b".
K		2 positions. Spring offset in position "0". Operated in position "b".
		Operated in position "a".

2 position spools		
Code	Spool position	
B		2 positions. Spring offset in position "b". Operated in position "a".
D		2 positions. Operated in position "a" or "b". No center or offset position.
H		2 positions. Spring offset in position "a". Operated in position "b".

1) Consider specific spool position.

Further spool types, styles, and combinations on request.

The flow curve diagram shows the flow versus pressure drop curves for all spool types. The relevant curve number for each spool type, operating position and flow direction is given in the table below.

Spool	Position "b"			Position "a"			Position "0"				
	P-A	B-T	P-B	P-B	A-T	P-A	P-A	P-B	A-T	B-T	P-T
001	2	2		2	2						
002	1	4		1	4		1	1	5	5	2
003	3	4		3	6				7		
004	2	3		2	3				7	7	
005	2	2		2	2		12				
006	1	4		1	4		7	7			
007	3	2		2	2			3		2	7
010	3			3							
011	2	2		2	2				14	14	
014	3	2		2	2		3		2		7
015	3	6		3	4					7	
016	2	2		2	2			12			
020B	4	4		2	3						
026B	4			4							
030B	2	3		1	2						
081	13	13		13	13						
082	13	13		13	13				1)	1)	
101B	11	10		10	9						
102	1	4		1	4		5	5	8	8	6
	P-B	A-T		P-A	B-T		P-A	P-B	A-T	B-T	P-T
008	4	5		4	5						9
009	5	5		6	7						7

Spool	Position "b"			Position "a"		
	P-A	P-B	A-B	P-B	A-T	
021	2	4		4	2	
	P-A	B-T		P-A	P-B	A-B
022	6	2		5	2	

Flow curve diagram

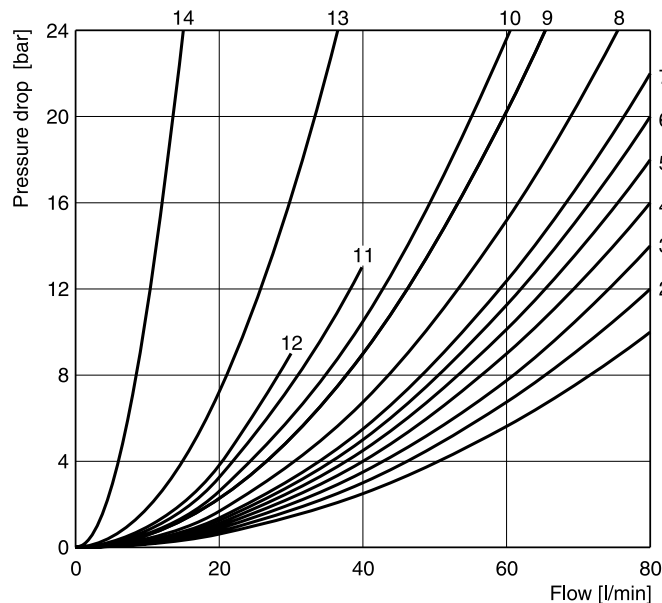

All characteristic curves measured with HLP46 at 50 °C.

1) Only for pressure compensation, no high flow possible.

The diagram below specifies the shift limits for valves with AC and DC solenoids. The specifications apply to a viscosity of 40 mm²/s and balanced flow conditions. The

shift limits can be considerably lower at unbalanced flow conditions. To avoid flow rates beyond the shift limits, a plug-in orifice can be inserted in the P-port.

Shift limit diagram with DC solenoid

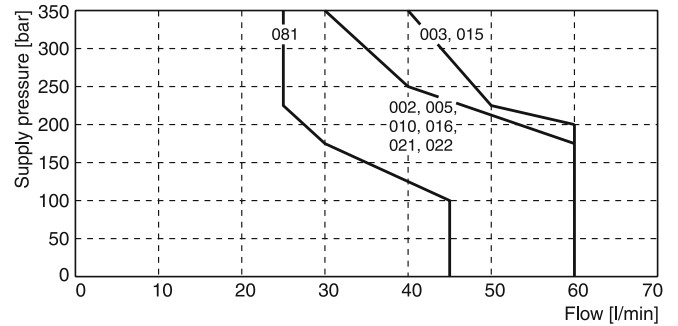
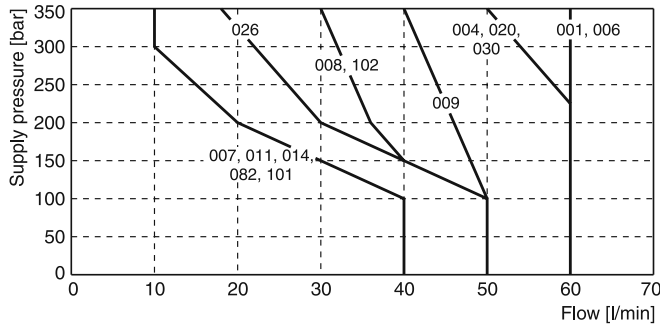

Measured with HLP46 at 50 °C, 90 % U_{nom} and warm solenoids

Shift limit diagram with AC solenoid

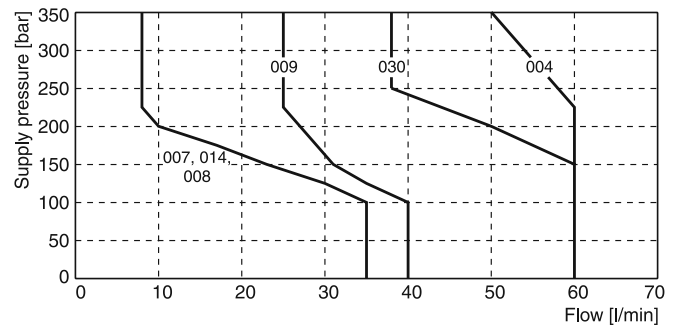
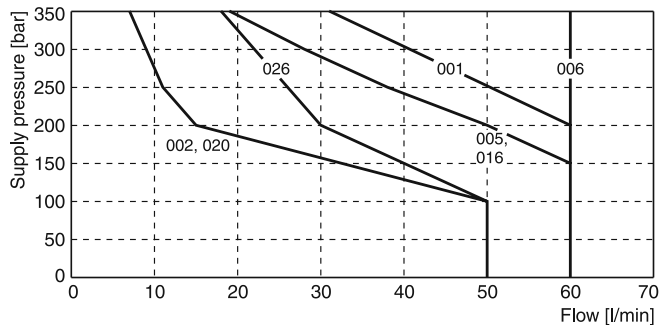

Measured with HLP46 at 50 °C, 95 % U_{nom} and warm solenoids

Dimensions
B, E -style

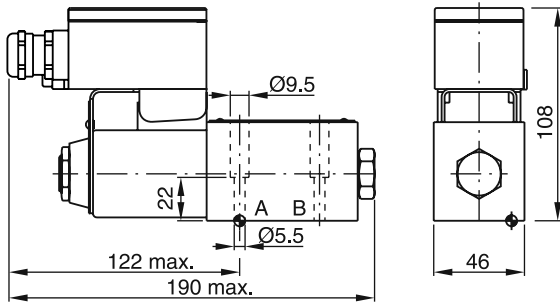



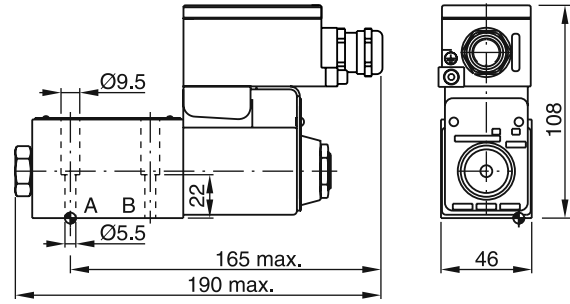

H, K -style

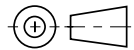
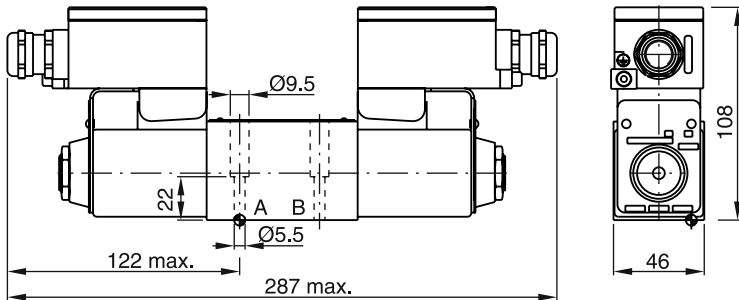

C, D -style

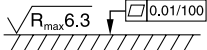

Surface finish	 Kit	 4x M5x30 ISO 4762-12.9	 7.6 Nm ±15 %	 Kit NBR
	BK375			NBR: SK-D1VW-N-91 FPM: SK-D1VW-V-91