

Design and dimensions

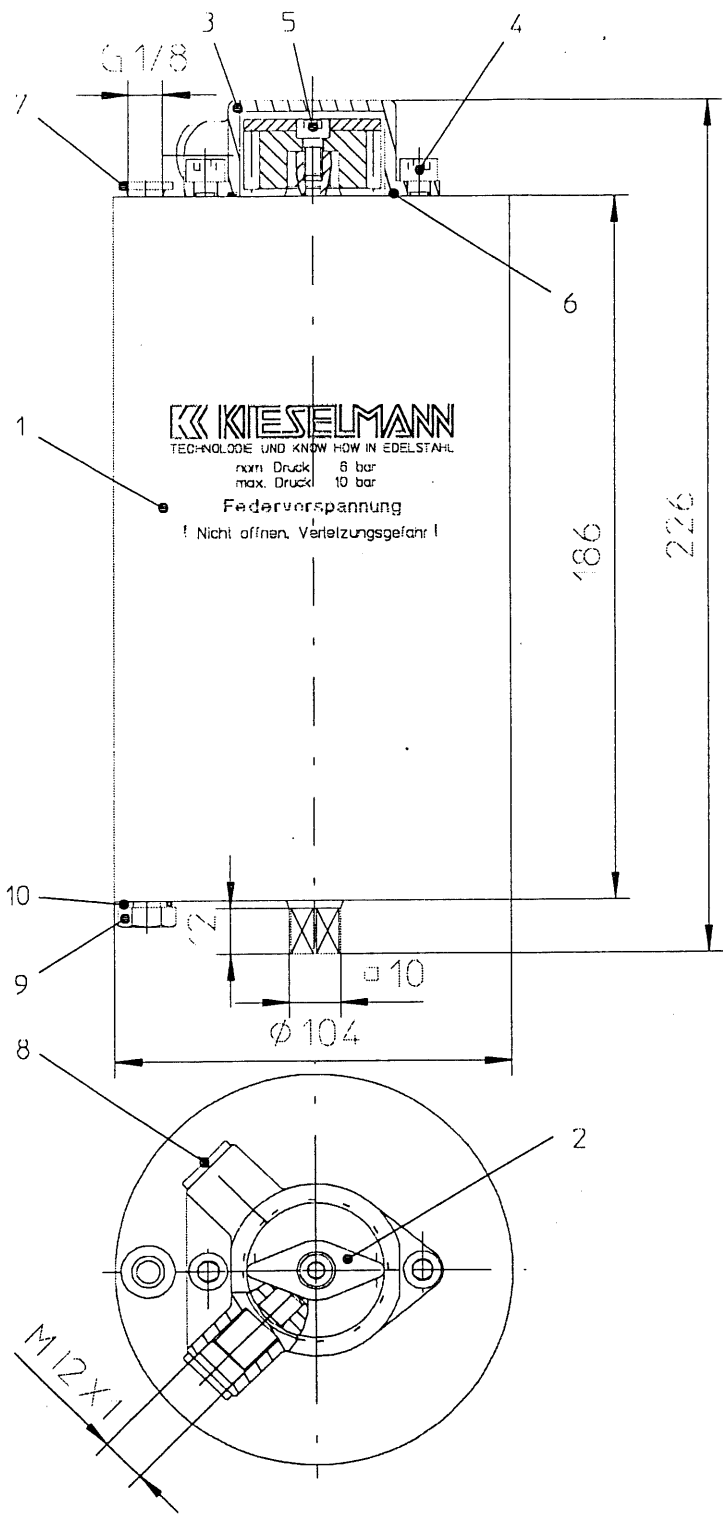

Item no.	Description
1	Actuator
2	Position indicator
3	Signalling unit
4	Hexagon socket screw
5	Hexagon socket screw

Item no.	Description
6	O-ring seal
7	Vent plug
8	Plug
9	Waste air plug
10	Packing ring

Removal and maintenance

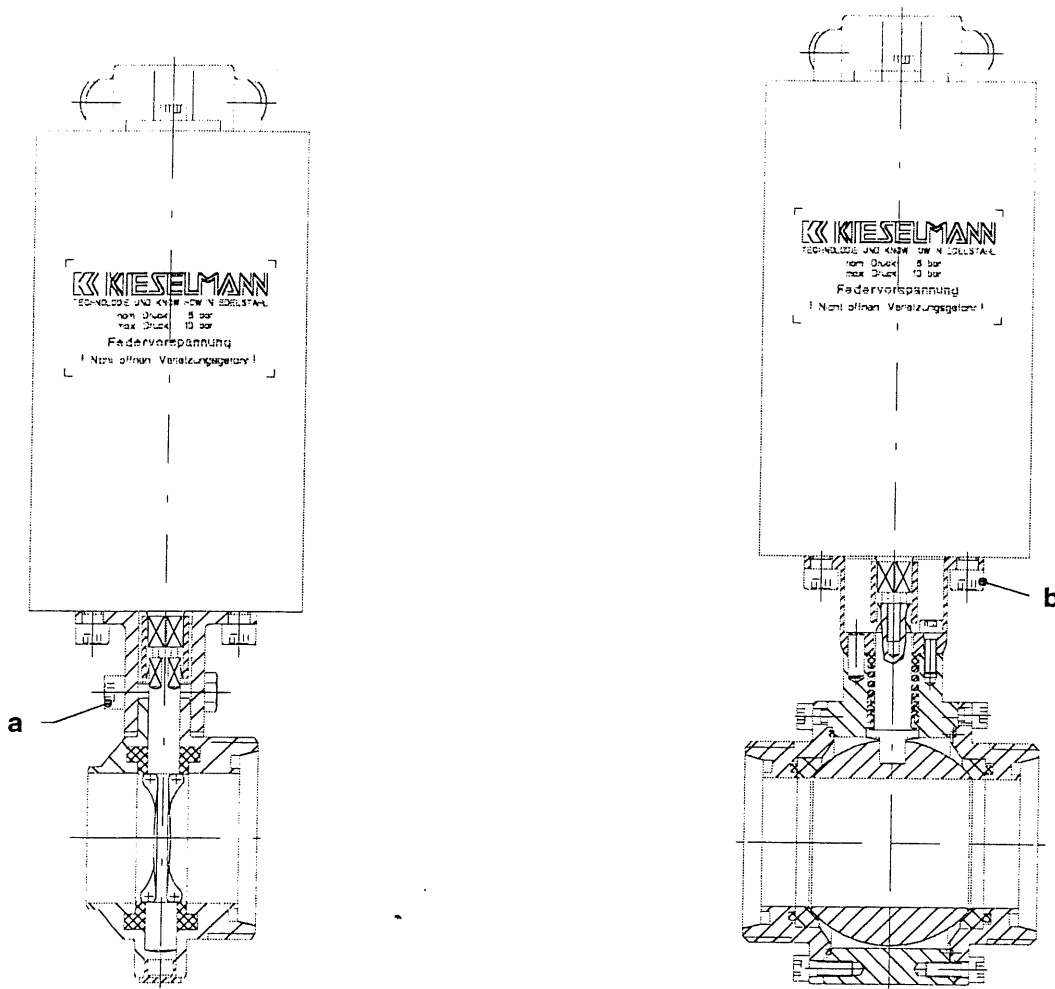

Butterfly valves

The actuator is clamped onto the butterfly valve using a holding flange. To remove the actuator, unscrew the two fastening screws (a) on the holding flange by approx. one turn. The screws do not need to be unscrewed all the way and can remain on the holding flange. You can then remove the actuator from the valve in one piece.

When mounting the actuator, care should be taken to ensure that the position of the rotary flap is correctly set. The following describes the position of the marking notch on the shaft end of the various signs:

air-open/spring-close:	marking 90 degrees relative to pipeline axis
air-close/spring-open:	marking in the direction of the pipeline axis
air-open/air-close:	marking 90 degrees relative to pipeline axis

When the connection hub has been attached to the square bar of the rotary flap, the drive is inserted by the square bar into the free end of the connection hub up to the stop. The screws on the holding flange are tightened with a torque of approx. 12 Nm.

Leakage butterfly valves and ball valves

The actuator is clamped onto the valves using a holding flange. To remove the actuator, fully unscrew the two screws (b) on the holding flange. You can then remove the actuator from the valve in one piece. When mounting the actuator, care should be taken to ensure that the position of the rotary flap or ball (as applicable) is correctly set. The position of the marking notch on the shaft end is set as described in the adjacent section (installation of the butterfly valve). When the connection hub has been attached to the square bar of the rotary flap or the switching axis of the ball valve (as applicable), the drive is inserted by the square bar into the free end of the connection hub up to the stop. The screws on the holding flange are tightened with a torque of approx. 12 Nm.

The actuator should preferably be mounted in such a way that the pneumatic connection and the holders for the proximity initiators are parallel to the pipeline axis. They can also be mounted at an angle of 90 degrees; in this event, however, the red position indicator on the actuator must be rotated by 90 degrees.